

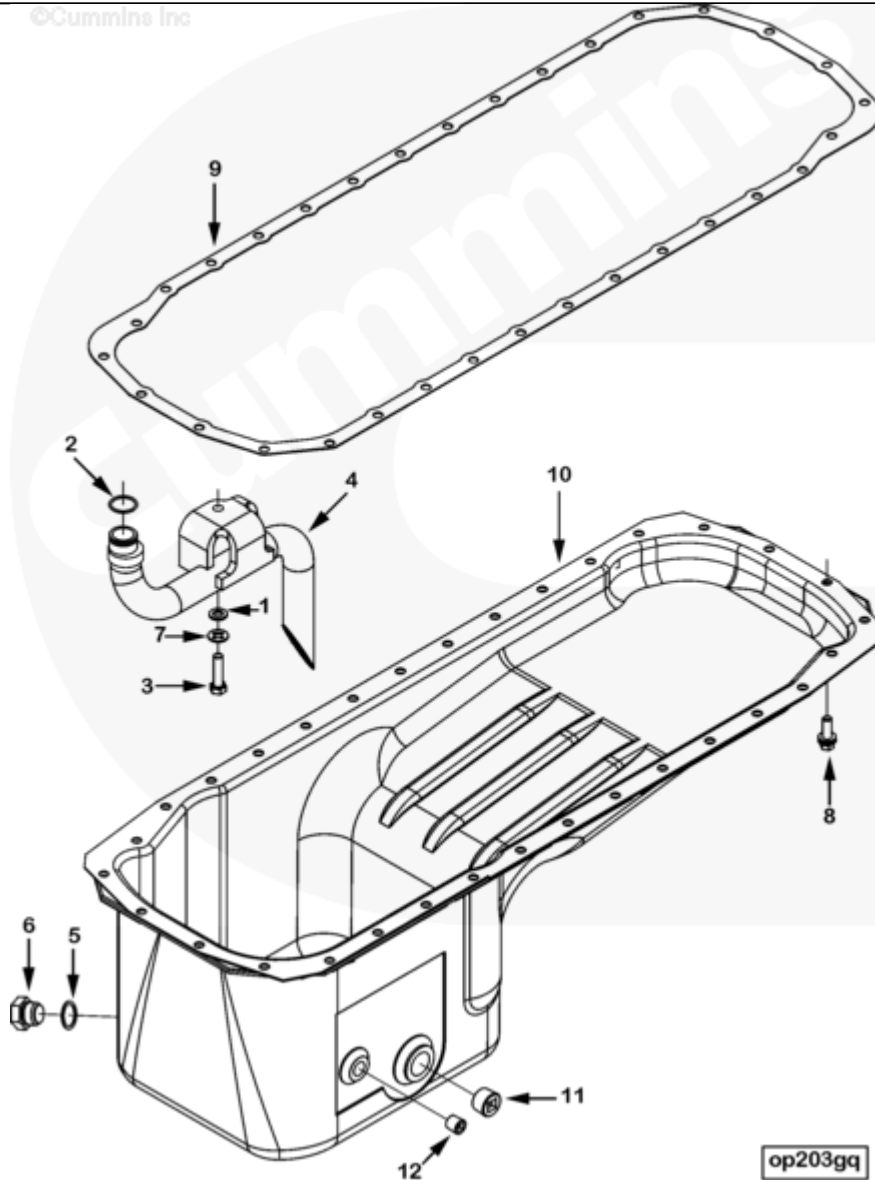

Parts Catalog - Option Detail

Electronic Parts Catalog - Option Detail				
Option	Group	Graphic	Film Card	Date
OP2154-02	07.01	op203gq	II	03-NOV-09
Engines	ISM CM570, ISM CM570/870, ISM CM875, ISM CM876, ISM CM876 E, ISM11 CM876 M103, ISM11 CM876 SN, M11 CELECT, M11 CELECT PLUS, M11 MECHANICAL, QSM11 CM570, QSM11 CM876			



SMALL | MEDIUM | LARGE

Cart	Ref No	Part Number	Part Description	Required	Remarks
View My Cart					
		OP2154-02	Oil Pan		

					Oil Pan
					Sump Location: Front
					Material: Stamped Steel high
					High Oil Pan Capacity:
					34.065 L (9.0 Gallons)
					Low Oil Pan Capacity:
					26.495 L (7.0 Gallons)
					Angularity Limits: 42
					42 Degrees Front Down
					40 Degrees Rear Down
					40 Degrees Fuel Pump Down
					45 Degrees Exhaust Down
					Drain Location: (1 in. -18)
					Bottom and Side
					Lube Oil Suction Tube:
					Block Mounted
					Noise Panel Provision: Yes
					Oil Heater Boss: (1 in. -NPT)
					Left Side
					Oil Temperature Boss:
					(1/2 in. -NPT) Left Side
					Low Oil Level Sensor Boss:
					(3/8 in. -NPT) None
					Rust Inhibitor Required:
					Zinc Nickel Plating
					Indented Bosses: Yes
<input type="checkbox"/>	1	3009330	Plain Washer	1	M10.
<input type="checkbox"/>	2	3032787	O-Ring Seal	1	

<input type="checkbox"/>	3	3254405	Hexagon Head Cap Screw	1	M10 X 1.50 X 40.
<input type="checkbox"/>	4	3328583	Lubricating Oil Suction Tube	1	
<input type="checkbox"/>	5	67946	Plain Washer	1	1 1/32 in.
<input type="checkbox"/>	6	3055069	Threaded Plug	1	1 - 18 UNS.
<input type="checkbox"/>	7	3896022	Cap Screw Retainer	1	
		4952187		1	
<input type="checkbox"/>	8	3896723	Hexagon Flange Head Cap Screw	32	
<input type="checkbox"/>	9	3401290	Oil Pan Gasket	1	
<input type="checkbox"/>	10	4952785	Pan , Oil Top Level Assembly	1	
<input type="checkbox"/>	11	3008470	Pipe Plug	1	1 NPT.
<input type="checkbox"/>	12	3008468	Pipe Plug	1	1/2 NPT.

© 2019 Cummins Inc., Box 3005, Columbus, IN 47202-3005 U.S.A.
Terms of Use and Disclaimers | Recommended System Requirements
Need Assistance? Please click on the Contact Us button in the top right corner of any page.